

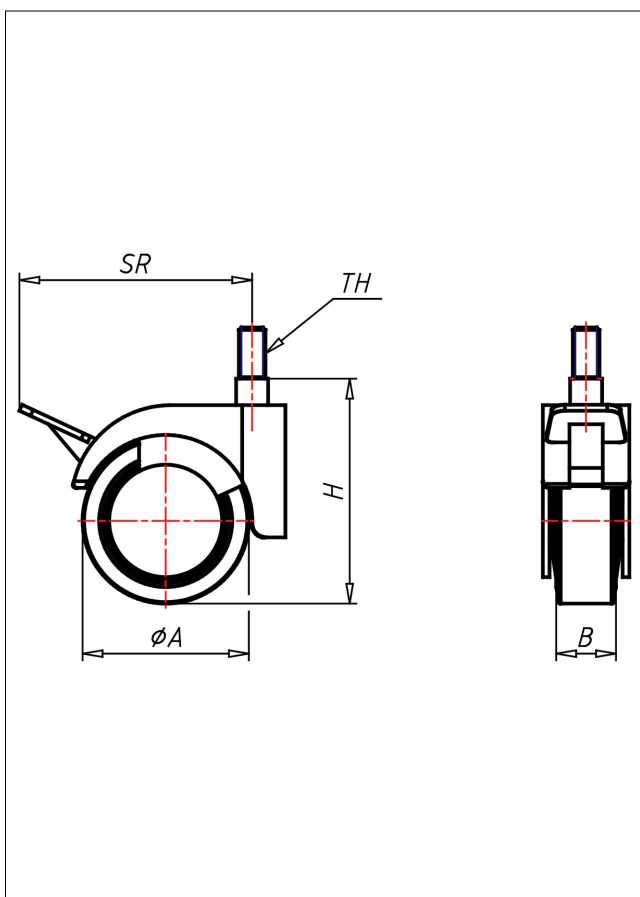

476 M8/M10/M12 DE

Lenkrolle mit Radfeststeller



475-DE



+60 °C
-20 °C

max.
40 kg



Gehäuse: Zinkdruckguss - verchromt
Schwenklager mit kombiniertem
Gleit-Kugellager
Felge Polyamid 6
elastischer PUR-Reifen - spurfrei
Radfeststeller glasfaserverstärkt
Radachse verschraubt

Technische Details

| | |
|--------------------------------|---------------|
| ORDERNO (Artikel-nummer) | 476 M12 50 VK |
| WDAB (Rad-Ø A x Breite B / mm) | 50x18 |
| LC (Tragkraft / kg) | 40 |
| H (Bauhöhe H / mm) | 68 |
| TH (Gewinde / mm) | M12x15 |
| SR (Schwenkradius / mm) | 70 |
| WB (Radlager) | Kugellager |